



USN

|  |  |  |  |  |  |  |  |  |  |
|--|--|--|--|--|--|--|--|--|--|
|  |  |  |  |  |  |  |  |  |  |
|--|--|--|--|--|--|--|--|--|--|

10EC/TE61

**Sixth Semester B.E. Degree Examination, Jan./Feb. 2021**  
**Digital Communication**

Time: 3 hrs.

Max. Marks: 100

**Note: Answer FIVE full questions, selecting atleast TWO questions from each part.**

**PART – A**

- 1 a. With neat block diagram, explain the operation of digital communication system. Explain the functioning of each block. (06 Marks)  
b. Explain the term quadrature sampling of band pass signal with help of spectrum and block diagram. (08 Marks)  
c. A signal  $x(t) = 2\cos 400\pi t + 6\cos 640\pi t$  is ideally sampled at  $f_s = 500\text{Hz}$ . If the sampled signal is passed through an ideal low pass filter with cut off frequency  $f_c = 400\text{Hz}$ . Find :  
i)  $X(f)$  and sketch its spectrum  
ii) Sampled signal  $X\delta(f)$  and sketch its spectrum  
iii) The components that will appear at the filter output. (06 Marks)
- 2 a. Derive an expression for maximum signal to quantization noise ratio for PCM system that employs linear quantization techniques. What will be the  $[S/N]_{\text{dB}}$  if the destination power and signal amplitude are normalized. (08 Marks)  
b. With a suitable block diagram, explain the functioning of a PCM system. (06 Marks)  
c. A PCM system uses a uniform quantizer followed by a 7 bit encoder. The bit rate of the system is equal to  $60 \times 10^6$  bits/sec. i) What is the maximum message bandwidth for which the system operates satisfactorily. ii) Determine SNR when a full load sinusoidal wave is considered. (06 Marks)
- 3 a. Explain the principles of delta modulation, with relevant figures and mathematical expressions explain the functioning of DM transmitter and receiver. (08 Marks)  
b. For a binary sequence 111000110110. Draw the waveforms for the following :  
i) Digital formats  
ii) RZ unipolar  
iii) RZ polar  
iv) NRZ bipolar  
v) Manchester coding. (06 Marks)  
c. Obtain an expression for the power spectral density of NRZ polar wave form. (06 Marks)
- 4 a. The binary data 001101001 are applied to the input of a duobinary system. Construct the duobinary coder output and corresponding receiver output assume the precoder is used. (04 Marks)  
b. What is an eye pattern? Explain how it is helpful in understanding the ISI problem. (08 Marks)  
c. What is ISI? Derive an expression for Nyquist pulse shaping criteria for distributionless base band binary transmission. (08 Marks)



PART – B

- 5 a. Explain with neat block diagram the coherent QPSK transmitter and receiver. For a given binary sequence 01101000. Draw the signal space representation and relevant QPSK wave forms. (10 Marks)
  - b. Explain M-ary modulation techniques. (06 Marks)
  - c. Compare binary PSK and QPSK schemes. (04 Marks)
- 6 a. Consider the signal  $S_1(t)$ ,  $S_2(t)$ ,  $S_3(t)$  and  $S_A(t)$  as given below in Fig.Q6(a) :

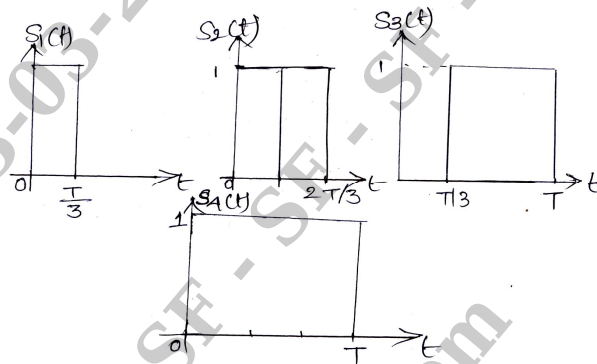

Fig.Q6(a)

- Find an orthonormal basis for these set of signal using Gram-Schmidt orthogonalization procedure. (10 Marks)
- b. With neat block diagram, explain the principle of detection and estimation. (05 Marks)
  - c. With vector space representation of message symbols.  $M = 3$ , briefly explain geometric representation of message vectors. (05 Marks)
- 7 a. Derive an expression for probability of error in binary QPSK generation and coherent detection. (08 Marks)
- b. Briefly explain the properties of matched filter. (06 Marks)
- c. A binary data is transmitted using ASK over a AWGN channel at a rate of 2.4 Mbps. The carrier amplitude at the receiver is 2mv. The noise power spectral receiver is 1MV. The noise power spectral density  $\frac{N_0}{2} = 10^{-15}$  watts/Hz. Find the average probability of error if the detection is coherent. (take  $\text{erfc}(5) = 3 \times 10^{-6}$ ). (06 Marks)
- 8 a. Explain the principle of direct sequence spread spectrum communication system. (06 Marks)
- b. What is spread spectrum? What is the role of PN code in spread spectrum? (04 Marks)
- c. Explain the properties of maximum length sequence generated from 3 stage shift register with linear feedback. Verify these properties and determine the period of the given PN sequence 01011100101110. (06 Marks)
- d. Distinguish between slow frequency hopping and fast frequency hopping. (04 Marks)

\*\*\*\*\*